

2019

University of North Carolina Wilmington
Master of Science in
Computer Science and Information Systems
Proceedings

<https://csbapp.uncw.edu/mscsis>

INTERNET OF THINGS AND ITS APPLICATION TO AGRICULTURE IN DEVELOPING COUNTRIES

Daniel Elili

A Capstone Project Submitted to the
University of North Carolina Wilmington in Partial Fulfillment
of the Requirements for the Degree of
Master of Science

Department of Computer Science
Department of Information Systems and Operations Management

University of North Carolina Wilmington

2017

Approved by
Advisory Committee

Dr. Cem Canel

Dr. Douglas M. Kline

Dr. Devon M. Simmonds, Chair

Accepted By

Dean, Graduate School

ABSTRACT

Despite playing a substantial role in their economies, the agricultural sector of developing countries has not been exploited compared to developed countries. Developed Countries apply modern information and communication technologies in the form of Internet of Things (IOT) technologies to agriculture. This is also known as smart farming. IOT technologies have the potential to positively impact agriculture in developing countries. Some of the problems the agricultural sectors in developing countries face include; climate change, storage, wastage, low returns, pests, diseases and so much more. This project analyzes and talks about internet of things and how the concept can be applied to storage in agriculture to help farmers in developing countries reduce wastage in order to maximize profits. This project looks at numerous applications of IOT technology in agriculture, the challenges farmers in developing countries encounter and how internet of things benefit farmers in developing countries. In this Project, Nigeria which as a country in West Africa will be used as a case study.

Acknowledgements

The quality of this project was greatly enhanced by the gracious assistance of many individuals.

The success of any project depends largely on the encouragement and guidelines of many others.

I would like to take this opportunity to express my gratitude to the people who have been instrumental in the successful completion of this project. I would like to show my greatest appreciation to my committee chairman Dr. Devon Simmons. I cannot say thank you enough for his tremendous support and help. Without his encouragement and guidance this project would not have materialized. Other committee members, Dr. Douglas Kline, my mentor who has been the constant source of encouragement throughout MS CSIS program, offering me professional advice and counselling whenever I was stuck at a crossroad. and Dr. Cem Canel who offered great input during the presentation and writing portion of the project. Thank you to my parents for supporting me emotionally and financially throughout my education. Their patience, while completing this project, has been greatly appreciated. Thank you to all my friends, co-workers who gave me ideas and served as inspiration while working on this project.

Without the support of those mentioned, this project would not have been possible.

Table OF Contents

ABSTRACT.....	2
Acknowledgements.....	3
CHAPTER ONE	6
1.1 INTRODUCTION	6
1.2 Challenges of IoT in Agriculture	8
a. ILLITRACY.....	8
b. POOR FINANCING.....	9
c. POVERTY.....	9
d. INDUSTRIALIZATION	10
e. ELECTRICITY.....	11
f. LACK OF SCIENTIFIC AND TECHNICAL KNOW-HOW	12
1.3 Benefits of IoT	14
1.4 STATEMENT OF PROBLEM AND RESEARCH OBJECTIVES.....	18
1.5 BENEFITS OF STUDY.....	19
1.6 METHODOLOGY	20
CHAPTER TWO.....	21
Application of IoT in Agriculture	30
ZigBee.....	30
BeanIoT.....	31
How they work to provide precision agriculture.....	32
VeriSense.....	33
Plastic sensor circuit.....	34
CHAPTER THREE	36
THE STATE OF AGRICULTURE IN NIGERIA.....	36
Overview	36
Agricultural Challenges In Nigeria	40
CHAPTER FOUR	44
Implementation: IoT Storage Solution	44
In this section I develop an IoT solution for the proper storage of farm products. This section includes	44
Deployment Architecture.....	44

Storage System Solution Architecture For a 1200 per 1200 Sqr ft Storage Room	48
HARDWARE SYSTEM REQUIREMENT	49
Hardware system Requirement Include.....	52
Software Requirements	52
Software system Requirement Include	52
Cost of Implementation	58
CONCLUSION	66
References	68

CHAPTER ONE

1.1 INTRODUCTION

Internet of things (IOT) is a network where objects, animals or people are equipped with unique devices capable of data transmission over Internet network without the need for human to human or human to computer interaction (Gluhak et al., 2011). IOT refers to a network of objects and is often a self-configuring wireless network (Patli et al, 2012). Internet of things is the inter-networking of physical devices, vehicles, buildings and other items embedded with electronics, software, sensors, actuators and network connectivity which enable these objects to collect and exchange data (Brown Eric, 2016).

Over 13.4 billion devices were connected to the Internet as part of Internet of things in 2015 and there is an expected increase by 185% to 38.5 billion devices by year 2020 (Juniper Research, 2015). Internet of things can be used in almost every area of our present society. Among the major areas are Smart Health Care, Smart Cities, Smart Industry, Autonomous Vehicles, Smart Homes, Smart Agriculture and others (Shang et al., 2015; Khan et al., 2012).

Major I.O.T technologies include radio frequency identification technology, sensor technology, sensor network technology and internetwork communication. All of which have been involved in the four links of Internet of things industrial chain, namely, identification, sensing, processing and information delivery.

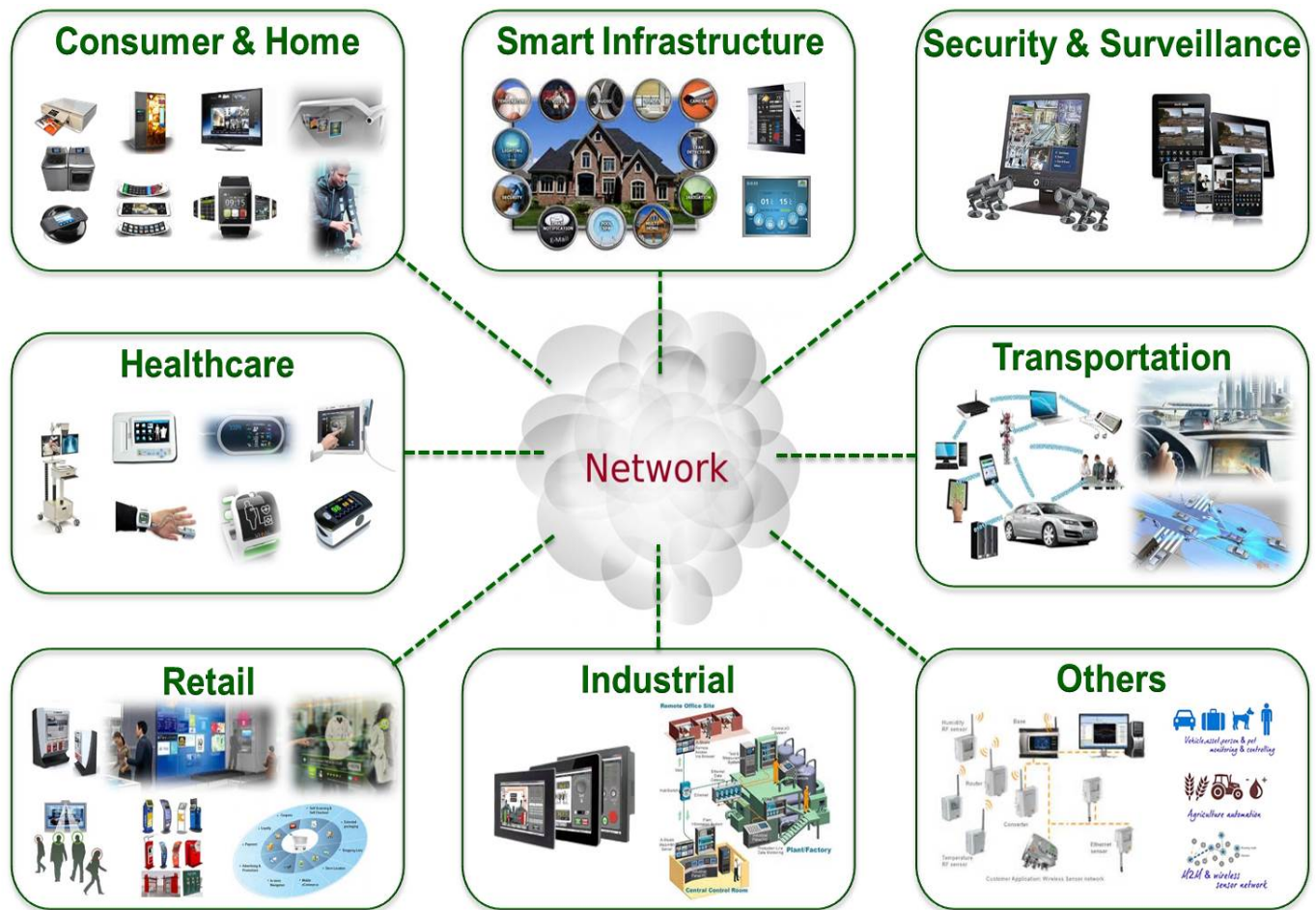

Vivante and the Vivante logo are trademarks of Vivante Corporation. All other product, image or service names in this presentation are the property of their respective owners. © 2013 Vivante Corporation

Figure 1: Internet of things major application areas (Vivante Corpration)

1.2 Challenges of IoT in Agriculture

In developed countries, at retail level, large quantities of food are wasted due to poor post-harvest storage and management (United Nations). Consumers in rich countries are generally encouraged to buy more food than they need and fail to plan their food purchases properly. In developing countries, the problem is essentially due to inadequate harvest techniques, poor post-harvest management, and lack of suitable infrastructure, processing and packaging, lack of marketing information.

This is to show that developing countries especially African countries are lagging mostly because of technology and technical know-how of these farmers. Below are some of the challenges being faced in developing countries like Nigeria:

a. ILLITERACY

The greatest number of dedicated full-time farmers in Nigeria can neither read nor write. The local farmers there are even as uninformed as they lack modern agricultural education.

The highpoint of illiteracy there, is Nigeria's total negligence and, or her non-usage of native languages in the nation's pursuits for modern education. For in this modern world, people that still studies in foreign languages have not really started learning and this level of illiteracy and

unawareness do often constitute some serious set-backs, even in Nigeria's food production efforts.

b. POOR FINANCING

This is another factor affecting the development of agriculture in Nigeria. Due to lack of proper financing, many farmers are not able and motivated to go into commercial agriculture. Instead these farmers practice subsistence agriculture which is limited to their household consumption alone and therefore cannot reach the full potential of agriculture. Lack of funding subjects the farmers to poverty and make them unable to secure collaterals that they can use to obtain loan. They do not have access to credit facilities and are therefore not able progress in farming. These farmers can not employ agricultural specialist to help them and they cannot afford to purchase the IOT devices that will make their work easier and faster.

c. POVERTY

In today's Nigeria, one of the major problems of food production is poverty. On the other hand, one of the simplest and a doubtless truth that you can easily know about Nigeria is the fact that over 75% of her rural dwellers are full-time farmers.

Another doubtless truth that you can also discover there is that Nigeria's present inability to, even solve her own problems of food and agriculture, is not as a result of her peoples' laziness;

or say a matter of the nation being naturally unblessed. Nigerian farmers and Nigerians in general are really hard-working and industrious.

A very great variety of delicious types of organic foods, fruits, vegetables and cash-crops abound in the country. In fact, the nation is so extremely blessed, and there are very large acres of fertile agricultural lands all around the country.

But to me, Nigerians and other developing countries are not really lacking food. What they really lack there is the money to buy the food; the money to produce the food; and, or even the money to procure small piece of land to grow the food and the money to acquire the IOT devices to practice smart farming.

d. INDUSTRIALIZATION

Modern Conversions and Privatizations of Food and Agriculture into a very Big and Expensive Industry or Conglomerate, is also of the Major Contributors to Nigeria's Food and Agricultural Set-backs. In one hand, the Modern Global Waves of Industrialization and Privatization of Food and Agriculture Really Produces Surplus Food that is more than enough to Feed, even the Entire World Population. On the other hand, Food and Agricultural Industrialization and Privatization, really Added Greatly to Global Hunger and Poverty. The Reasons are because Agricultural Industrialization and Privatization:

- Results in an Uneven Distribution of Food
- Uses much of the Produced Food in Feeding Animals
- Is Wasteful and Destructive as it is only after Quantity.
- Favors the Haves and Disfavors the Have-nots
- Adds Hidden Taxes to Prices of Food
- Is Very Expensive and Uneconomical
- It Results in Total Loss of Rural Jobs like farming.

When the country is not focusing on agriculture, it will be difficult to use IOT technology in the agricultural sector.

e. ELECTRICITY

IOT devices are usually powered by electricity, all though some of these sensors or GPS tracking devices uses rechargeable batteries, they also need electricity to charge them. In rural areas where these farmers stay, have no access to electricity supply. Farmers have to travel on a long distance to get electricity supply to charge their phones.

Electricity supply is not stable in the city not to talk of rural areas where the farmers stay. Every home in the city has a standby generator that is used because the supply of electricity is not stable compared to developed countries. Devices like laptops, desktop and mobile phones need

electricity to function. So, without electricity, there will be no use for IOT devices in the agricultural sector in Nigeria.

f. LACK OF SCIENTIFIC AND TECHNICAL KNOW-HOW

Most farmers are illiterates, they cannot read, and they cannot write. Farmers will not be able to understand the IOT technology. In Nigeria, scientific and technological know-how is relatively very low. Many schools there in Nigeria do not even have science laboratories. Hence, a great majority of students there rather theorize sciences than practice them.

In fact, this problem of Nigeria's under-development in science and technology often leave the country to depend largely on importation instead of production and exportation. And this equally, is part of the major problems and challenges of the country's food and agricultural developments.

Developing countries face problems in developing and adopting IOT for Agriculture and Rural Development. Significant "wrong" (non-optimal) IOT development and implementation decisions are prevalent. They are extremely costly in economic and scarce human capital terms. Not least they are continuously resulting in considerable loss of benefit and opportunity.

End-Users are the key factor in defining the needs and critical success factors for IOT development and implementation. "End User" lack of IOT awareness does not seem to be a

significant obstruction while lack of their involvement is. “End User” complaints of “ICT related waste of time” seem to be diminishing in importance as an adoption constraint.

The constant oversupply of IOT innovations and cost reductions blended with the ever- changing information and Internet characteristics emphasize the critical need for an “IOT Intermediary” and training.

This can be provided by an Extension officer, scientist, consultant, etc. In this situation capable End Users are becoming an influential source of innovation and information. Their role as “agents of change” is becoming essential. A lack of “between End User” information exchange and “training” were indicated in this situation as effective adoption impediments.

Presenting a new technology to farmers poses obstacles. Other adoption and distribution problems usually encountered are listed below:

i. Not all farmers are interested in a computerized managerial information system. Some are satisfied with cost accounting at seasons’ end, sometimes not even that.

ii. Personal impediments of various kinds.

iii. Personal preferences. There are farmers who have tried to use Information Technology and decided to quit because they did not find it user-friendly enough, special needs were not met, etc.

iv. Dissatisfied farmers end up discouraging others from using Information Technology, even after installation.

v. Marketing of IOT to farmers is non-existent.

vi. Awareness of managerial information systems profits is limited, resulting in situations where they are yet to be adopted.

vii. Experience shows that farmers unassociated with the extension service are left behind professionally, which includes the use of IT related technology.

1.3 Benefits of I.O.T

Food storage allows food to be eaten for some time (typically weeks to months) after harvest rather than solely immediately. It is both a traditional domestic skill and, in the form of food logistics, an important industrial and commercial activity. Food preservation, storage, and transport, including timely delivery to consumers, are important to food security, especially for

majority of people throughout the world who rely on others to produce their food. Food is stored by almost every human society and by many animals.

IoT technologies have the potential to alleviate poverty and increase the standard of living of the rural farmers. For example, organic greenhouses make it possible to grow a wide range of crops that can not only be consumed locally but also for export to other nations. This enables farmers to generate extra income that help raise their standard of living and also to contribute to the gross domestic product (GDP) of the country. The rural farmers can also leverage the investments in the IoT technologies that support agriculture to improve the standard of living.

Agriculture is predominantly one of the main development accelerators of the Internet of Things (IoT). Up-to-date technologies are vital for agricultural produce manufacturers in supporting the rapidly growing population in developing countries and the world at large. Some of the benefits of IOT that will be discussed here are: In addition,

- IoT enables farmers to make the rural industry as much defensive and efficient as possible, as well as to generate new sources of income. That is, with the use of IOT devices farmers can detect theft of products and can also store and preserve perishable foodstuffs to prevent wastage and increase income for farmers.

- An intelligible practice of farming provides a chance to meet vital needs of society, thus protecting the ground and other natural resources for the generations to come. IoT helps to build up smart farms where it is possible to exercise control over every single process for delivering better decisions on waste reduction and crops increase through adequate storage.
- The use of temperature monitoring sensors like *Verisense* allows for online instant in-hutch temperature monitoring and sends automatic alerts in case the temperature drops or increases. This is beneficial in storing perishable products like tomatoes, fruits etc.
- Pest control will be made easy and stress-free with the use of IOT devices which will help farmers monitor insects' population remotely and protect seeding from these insects or pests.
- Since IoT technologies facilitate the tracking of farm products all the way to their destination, this is ideal for farm products that require further processing since the buyers can know in advance when the farm products will arrive and plan for the next processing steps in time. Since rural communities are sparsely populated, transportation of farm products can be a problem. IoT technologies can empower the transporters by

providing them with information of farmers who require transport. Therefore, transporters do not need to wait until they have a full truck load of farm products to start off, they can leave any time provided they are aware that there are farmers waiting for transport ahead. (Josephat Kalezhi and Nomusa Dlodlo, 2015)

Precision farming method incorporates data analysis for setting up an operation aiming to accelerate production of agricultural products based on the variability of managed cultivation as well as water and fertilizers consumption control. Activities of a kind create comprehensive facilities for economy considering the sole fact that 60% of water meant for irrigation is wasted for no reason. Besides that, for the security of foodstuff, IoT creates unique data networks making it possible for consumers to control the evolution of nutrition products in all its stages.

Precision agriculture can lead to bumper harvests even during times of drought. This will save countries from spending a lot of money importing agriculture products from other countries since the farmers will produce enough farm products to feed the nations.

Hence, the interest of the IoT is intertwined with human interaction and nature on a large scale.

Water quality and atmosphere changes monitoring, as well as solar radiation intensity meters are some of the most obvious domains to apply smart sensors. Immunity to weather impact and

the ability to transmit data for hundreds and thousands of kilometers makes IoT crucial when it comes to the agriculture modernization.

1.4 STATEMENT OF PROBLEM AND RESEARCH OBJECTIVES

Lack of proper storage facilities is resulting in rotting of food grains and spoilage of perishable food stuffs in developing countries [Deepak Kumar,2017]. A high volume of fruits, vegetables, and cash-crops is produced from Local Farming Communities. A great Percentage of these Farm Crops often get Damaged, spoilt or wasted before reaching the Final Consumers. In this situation, the major problem that these local farmers encounter is lack of proper food Storage or Processing Facilities [Deepak Kumar,2017]. According to an article published by **Bitzwatch Nigeria** in 2015, farming communities in sub-Saharan Africa have lost between 30 and 50 percent of fruits and vegetables to inadequate storage in the previous decade.

Internet of Things technology has been introduced into agriculture in developed countries, resulting in transformation and great improvement. In developing countries, a major agricultural challenge is to cultivate produce on the farm and deliver it to the end consumers for the best possible price and in best possible quality. In Nigeria which is a developing country, it is known that 60% of the farm produce do not get to the end consumer due to wastage led by inadequate

storage facilities and preservation [Jaspreet Aulakh and Anita Regmi]. The objectives of this project are to:

- 1) Highlight the needs and challenges faced in the agricultural sector of developing countries.
- 2) Identify the potential benefits of applying the Internet of Things to the agricultural sectors of developing countries.
- 3) Identify various Internet of things technology solutions and determine how these solutions can benefit the agricultural sector in one developing country.

1.5 BENEFITS OF STUDY

1. This project is an informational paper for individuals looking to expand their knowledge on existing Internet of things solutions with respect to agriculture.
2. This project highlights the state of agriculture in developing countries and their current needs.
3. This project serves as a guide to farmers, for deciding on an IOT storage solution for their agricultural business.

1.6 METHODOLOGY

The research methodology for this research project is based on the following;

- 1) A literature review - the area of IOT in agriculture and a study of the current economic situation of a developing country (National republic of Nigeria).
- 2) Interview Sessions - Qualitative interview sessions with local farmers, having firsthand knowledge of what goes on in the agricultural industry from local farmers, which include challenges encountered.
- 3) A look at some of the challenges faced by farmers in developing countries, and numerous ways to combat these problems.
- 4) Developing a IOT storage solution for a small scale farm in Nigeria.

CHAPTER TWO

LITERATURE REVIEW

Agriculture is well-thought-out to be one of the foundations of life for humans as it is the main source of food and other raw materials (Thomas Wessel, 1984). It plays a major role in the growth of every country's economy in the world today. It also provides large ample job opportunities to the people. Growth in agricultural sector is necessary for the improvement of economic condition of the country. Unfortunately, many farmers still use the traditional methods of farming especially in developing countries which results in low yielding of farm produce. But in developed countries, automation had been implemented and human beings had been replaced by automatic machineries, which has improved farm yield greatly. This implies that the implementation of modern science and technology in the agricultural sector is important for growth, development and for increasing agricultural yield. The use of wireless sensor network that collects data for different types of events and sends it to a server via a wireless protocol. The collected data provides information about different environmental factors that will help to monitor storage. Attack of wild animals and birds when the crop grows and thefts of crop at the stage of harvesting and beyond are different challenges farmers encounter while trying to preserve crops (resources). So, we look at how Internet of things can help mitigate these

challenges face by farmers during storage, which in turn affects the productivity of farming (Nikesh Gondchawar¹ and Prof. Dr. R. S. Kawitkar, 2016).

This is where Internet of things comes in, since it is the global system of interconnected computers that uses TCP/IP to link billions of devices worldwide.

Michael Tharrington talked about Smart farming to be a concept which is quickly catching on in the agricultural business. Offering high-precision crop control, useful data collection, and automated farming techniques, there are clearly many advantages that a networked farm has to offer. Of the many advantages Internet of things brings to the table, its ability to innovate the landscape of current farming methods is groundbreaking. Internet of things sensors capable of providing farmers with information about crop yields, rainfall, pest infestation, and soil nutrition are invaluable to production and offer precise data which can be used to improve farming techniques over time. New hardware, like the corn-tending Rowbot, is making strides by pairing data-collecting software with robotics to fertilize the corn, apply seed cover-crops, and collect information in order to both maximize yields and minimize waste.

Another direction in which smart farming is headed involves intensively controlled indoor growing methods. The OpenAG Initiative at MIT Media Lab uses "personal food computers" (small indoor farming environments that monitor/administrate specific growing environments)

and an open source platform to collect and share data. The collected data is termed a "climate recipe" which can be downloaded to other personal food computers and used to reproduce climate variables such as carbon dioxide, air temperature, humidity, dissolved oxygen, potential hydrogen, electrical conductivity, and root-zone temperature. This allows users very precise control to document, share, or recreate a specific environment for growing and removes the element of poor weather conditions and human error. It could also potentially allow farmers to induce drought or other abnormal conditions producing desirable traits in specific crops that wouldn't typically occur in nature.

With a future of efficient, data-driven, highly-precise farming methods, it is definitely safe to call this type of farming smart. We can expect Internet of things will forever change the way we grow food. (Michael Tharrington, 2015)

Different tools and techniques are available for development of farming. According to the UN Food and Agriculture Organization, in order to feed the growing population of the Earth, the world will need to produce 70% more food in 2050 than it did in 2006. To meet this demand, farmers and agricultural companies are turning to the Internet of things for analytics and greater production capabilities. Internet of things can play big role in increasing productivity, obtaining huge global market, idea about recent trends of crops. Internet of things is a network of

interconnected devices which can transfer data efficiently without human involvement. Today many agricultural industries turned to adopt Internet of things technology for smart farming to enhance efficiency, productivity, global market and other features such as minimum human intervention, time and cost etc. The advancement in the technology ensures that the sensors are getting smaller, sophisticated and more economic. The networks are also easily accessible globally so that smart farming can be achieved with full pledge. Focusing on encouraging innovation in agriculture, smart farming is the answer to the problems that this industry is currently facing. All this can be done using smart phones and Internet of things devices. Farmer can get any required data or information as well can monitor his agricultural sector (Malavade and Akulwar, 2016).

Food security is a major issue which will become more urgent and critical in the next decades due to the expected increase of the world population and the growing welfare in emerging economies. In the meantime, it is widely argued that we already have exceeded the carrying capacity of planet earth with the current way of agricultural production. Globalization, climate change, a shift from a fuel-based towards a bio based economy, and competing claims on land, fresh water and labor will complicate the challenge to feed the world without further pollution or resource depletion. It is expected that the Internet of things (Internet of things), where every

'thing' is uniquely identifiable, equipped with sensors and connected real-time to the internet, could contribute significantly to meet these challenges:

- Better sensing and monitoring of production, including farm resource use, crop development, animal behavior and food processing;
- Better understanding of the specific farming conditions, such as weather and environmental conditions, emergence of pests, weeds and diseases;
- More sophisticated and remote control of farm, processing and logistics operations by actuators and robots, e.g. precise application of pesticides and fertilizers, robots for automatic weeding;
- Improving food quality monitoring and traceability by remotely controlling the location and conditions of shipments and products;
- Increasing consumer awareness of sustainability and health issues by personalized nutrition.

The aim of the review was to provide an overview of Internet of things in agriculture and food to get a better insight in the use of Internet of things and how it could contribute to the aforementioned challenges (C.N. Verdouw et al, 2016).

IoT (Internet of Things) is transforming the agriculture industry and enabling farmers to contend with the enormous challenges they face (Ranjithkumarpv and Adarsh BU, 2014). The industry must

overcome increasing water shortages, limited availability of lands, difficult to manage costs, while meeting the increasing consumption needs of a global population that is expected to grow by 70% by 2050. New innovative Internet of things applications are addressing these issues and increasing the quality, quantity, sustainability and cost effectiveness of agricultural production. Today's large and local farms can, for example, leverage Internet of things to remotely monitor sensors that can detect soil moisture, crop growth and livestock feed levels, remotely manage and control their smart connected harvesters and irrigation equipment, and utilize artificial intelligence based analytics to quickly analyze operational data combined with 3rd party information, such as weather services, to provide new insights and improve decision making.

(Ranjithkumarpv and Adarsh BU, 2016)

Partha Pratim Ray a scholar in IoT research characterized Internet of things as the holder of key utility factors which is given below:

- Dynamic and self-adapting: Internet of things devices and systems should have the capability to dynamically adapt with the changing contexts and take actions based on their operating conditions, user's context, or sensed environment. For example, consider a surveillance system comprising of several surveillance cameras. The surveillance cameras can adapt their modes (to normal or infra-red night modes) based on whether it

is day or night. Cameras could switch from lower resolution to higher resolution modes when any motion is detected and alert nearby cameras to do the same. In this example, the surveillance system is adapting itself based on the context and changing (e.g., dynamic) conditions.

- Self-configuring: Internet of things devices may have self-configuring capability, allowing many devices to work together to provide certain functionality (such as weather monitoring). These devices can configure themselves (in association with Internet of things infrastructure), setup the networking, and fetch latest software upgrades with minimal manual or user intervention.
- Interoperable communication protocols: Internet of things devices may support an amount of interoperable communication protocols and can communicate with other devices and also with the infrastructure.
- Unique identity: Each of Internet of things device has a unique identity and unique identifier (such as IP address or URI). Internet of things systems may have intelligent interfaces which adapt based on the context, allow communicating with users and environmental contexts. Internet of things device interfaces allow users to query the devices, monitor their status, and control them remotely, in association with the control, configuration and management infrastructure.

- Integrated into information network: Internet of things devices are usually integrated into the information network that allows them to communicate and exchange data with other devices and systems. Internet of things devices can be dynamically discovered in the network, by other devices and/or network, and have the capability to describe themselves (and their characteristics) to other devices or user applications. For example, a weather monitoring node can describe its monitoring capabilities to another connected node so that they can communicate and exchange data. Integration into the information network helps in making IOT systems “smarter” due to the collective intelligence of the individual devices in collaboration with the infrastructure.
- Context-awareness: Based on the sensed information about the physical and environmental parameters, the sensor nodes gain knowledge about the surrounding context.

Some of the applications of IoT in agriculture include: Irrigation management system, Pests and disease control, Cattle Movement Monitoring, Water quality monitoring e.t.c.

(P.P Ray, 2017)

Wireless sensor networks (WSNs) and IoT might be great tools to monitor environmental parameters like temperature, humidity, climate change and plant growth in agricultural.

Precision agriculture is concerned with whole farm management aided by the information and

communication technology (ICT) to optimize returns on inputs while preserving resources with regards to crop science, environmental protection, and economics aspects. Thus, vital information can be provided in terms of farm record keeping, which will help improve decision making, foster a greater traceability process, and enhance the inherent quality and marketing of farm products.

However, success in greater application of ICT in agriculture will require addressing impediments to adoption and diffusion. Such impediments include the lack of awareness, low literacy, infrastructure deficiencies (e.g. lack of electricity to charge electronic gadgets), language and cultural barriers in ICT usage, the low e-inclusivity and the need to cater for the special needs of some users. The work reviews successful applications of ICT in agriculture and urges greater use of ICT-based interventions in agriculture as a vehicle for spurring rural development in Africa.

(Nomusa Dlodlo and Josephat Kalezhi, 2015).

Application of IoT in Agriculture

In this section, I look at systems that leverage IoT and how they are applied in the area of agriculture. Some IoT devices used by developed countries in agricultural storage include:

ZigBee

ZigBee is a low-cost, low-power, wireless mesh networking standard. The low cost allows the technology to be widely deployed in wireless control and monitoring applications, the low power-usage allows longer life with smaller batteries, and the mesh networking provides high reliability and larger range. As a brand-new information acquisition and the processing technology, the ZigBee has seeped gradually into the agricultural environmental monitoring domain. The ZigBee technologies allow the identification of pests in the crops, drought or increased moisture. Having such information at a real-time interval, automated actuation devices can be used to control irrigation, fertilization and pest control in order to offset the adverse conditions. This technology can be applied for wireless applications in agriculture. The ZigBee nodes can obtain the temperature, humidity and illumination information in real time, and then transfer to a remote monitoring center. (ZHU Xiaojing and LIN Yuanguai, 2012)

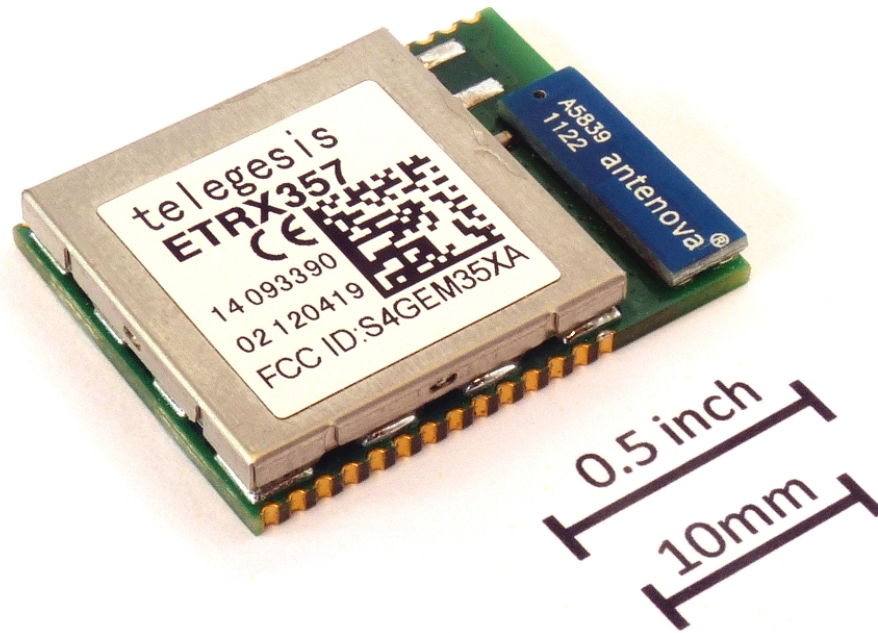

ZIGBEE

BeanIOT

Thumb-sized “plastic beans” are being filled with sensors and tossed into grain bins and storage facilities for precision agriculture, getting rid of the need for handheld devices or elaborate moisture monitoring systems.

The sensor pods can be dropped in an auger and become part of the grain storage. They are charged wirelessly and report data throughout the day to a smartphone or remote hub.

The beans can send out a signal when they read measurements outside of normal conditions.

How they work to provide precision agriculture

Designed to be worn, carried or deployed throughout the home or factory, each bean contains a Bluetooth radio, electronic compass, gyroscope and sensors. All the components “speak” with one another using an adaptive wireless mesh network of static or moving nodes.

Each device has a common array of environmental sensors, which, when combined with low-power wide-area networks, collects big data and works with cloud services for analysis, according to BeanIoT.

The beans will only send out information when necessary, staying dormant and conserving energy until then. If a problem exists, the bean wakes its neighbors and sends out wireless alerts. The battery charge lasts 14 months and recharges in a few hours.

BeanIoT is still in the process of being tested and rapidly prototyped, though Andrew Holland (BeanIoT CEO) plans to make the beans commercially available in the next two years. (*Chris Bennett, 2016*).

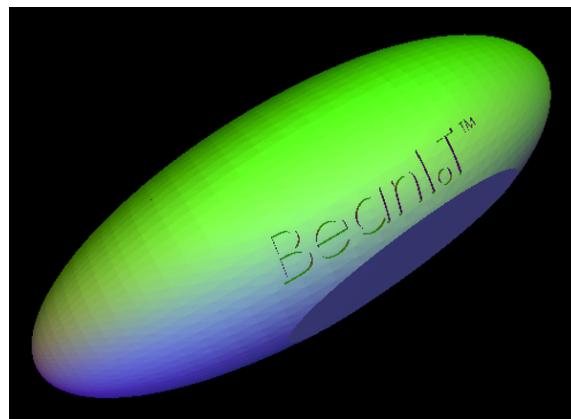

VeriSense

Preserving farm produce especially perishable goods fresh, the right temperature is key.

Intelligent network sensors can be used to monitor the temperature of locations these farm

products are stored. **Verisense** is a placeable environmental sensor which is created by

Verisolutions in Atlanta Georgia. Verisense is used to monitor the temperature and humidity of

mostly food items in restaurants to keep them fresh. Sensor sends information relating to

temperature and humidity. This system is found in the United states, but it can be adopted in

Nigeria which will help to boost the Nigerian farmers' storage facilities. This sensor is mostly used

in refrigerators. Some of its features include:

- Temperature monitoring (-40°C to +125°C)
- Humidity monitoring (0% to 100%)
- 5+ year battery life
- 100m range (extended with mesh network)



Plastic sensor circuit

The plastic sensor circuit measures the food's "environmental vitals" from within the packaging, and the resulting judgment on freshness can be read with a mobile phone.

The circuit works as follows: A tiny sensor measures conditions like acidity levels. The sensor produces an analog signal that is converted into a digital signal and broadcasts these signals over an RFID radio.

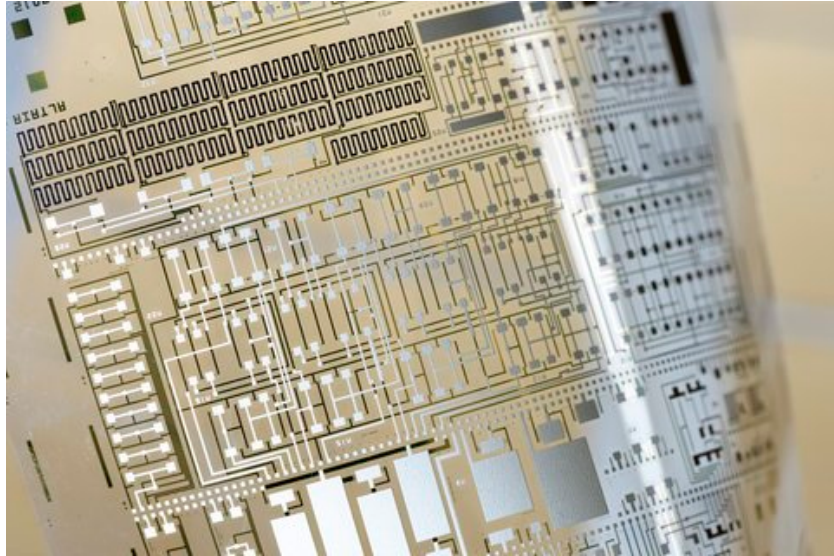

CHAPTER THREE

THE STATE OF AGRICULTURE IN NIGERIA

Overview

Nigeria is a country that depends heavily on crude oil for her revenues, Nigeria is still for the most part an agricultural society.

According to National Encyclopedia, it is known that approximately 70 percent of the Nigerian population engages in agricultural production but mostly in the practice of subsistence farming and not commercial farming. As at 1999, Agriculture provided Nigeria with 41 percent of her gross domestic product (GDP). This percentage represented a normal decrease of 24.7 percent from its contribution of 65.7 percent to the GDP in 1957. The decrease will continue because, as economic development occurs, the relative size of the agricultural sector usually decreases.

Nigeria's wide range of climate variations allows it to produce a variety of food and cash crops.

The staple food crops include cassava, yams, corn, coco-yams, cow-peas, beans, sweet potatoes, millet, plantains, bananas, rice, sorghum, and a variety of fruits and vegetables. The leading cash crops are cocoa, citrus, cotton, groundnuts (peanuts), palm oil, palm kernel, benniseed, and

rubber. They were also Nigeria's major exports in the 1960s and early 1970s until petroleum surpassed them in the 1970s. Chief among the export destinations for Nigerian agricultural exports are Britain, the United States, Canada, France, and Germany.

A significant portion of the agricultural sector in Nigeria involves cattle herding, fishing, poultry, and lumbering, which contributed more than 2 percent to the GDP in the 1980s. According to the UN Food and Agriculture Organization 1987 estimate, there were 12.2 million cattle, 13.2 million sheep, 26.0 million goats, 1.3 million pigs, 700,000 donkeys, 250,000 horses, and 18,000 camels, mostly in northern Nigeria, and owned mostly by rural dwellers rather than by commercial companies. Fisheries output ranged from 600,000 to 700,000 tons annually in the 1970s. Estimates indicate that the output had fallen to 120,000 tons of fish per year by 1990. This was partly due to environmental degradation and water pollution in Ogoniland and the Delta region in general by the oil companies.

Decline in agricultural production in Nigeria began with the advent of the petroleum boom in the early 1970s. The boom in the oil sector brought about a distortion of the labor market. The distortion in turn produced adverse effects on the production levels of both food and cash crops. Governments had paid farmers low prices over the years on food for the domestic market in order to satisfy urban demands for cheap basic food products. This policy, in turn, progressively

made agricultural work unattractive and enhanced the lure of the cities for farm workers. Collectively, these developments worsened the low productivity, both per unit of land and per worker, due to several factors: inadequate technology, acts of nature such as drought, poor transportation and infrastructure, and trade restrictions.

As food production could not keep pace with its increasing population, Nigeria began to import food. It also lost its status as a net exporter of such cash crops as cocoa, palm oil, and groundnuts. According to U.S. Department of State FY2001 Country Commercial Guide, Nigeria's total food and agricultural imports are valued at approximately US\$1.6 billion per year. Among the major imports from the United States are wheat, sugar, milk powder, and consumer-ready food products.

Efforts since the late 1970s to revitalize agriculture in order to make Nigeria food self-sufficient again and to increase the export of agricultural products have produced only modest results. The Obasanjo administration, however, has made agriculture the highest priority of its economic policy.

Agriculture is currently Nigeria's main focus for the future. As at May 2017, the Nigerian national assembly gave the agricultural sector 12 billion naira to improve the agriculture in Nigeria. The World Bank also approved \$200 million credit to support the Nigerian agricultural sector,

especially small and medium scale farmers in May 2017, which is meant to help increase agricultural productivity and production, improve processing and marketing, foster job creation and increase household income and livelihood in participating states.

In 1990, it was speculated that about 82 million hectares out of Nigeria's total land area of 91 million hectares were found to be arable, and merely 42 percent of this cultivable area was farmed. Much of this land was farmed under the bush fallow system, a process whereby land is left idle for a period to allow natural regeneration of soil fertility and replacement of soil nutrient.

It is believed that the agricultural sector is one of Nigeria's potential source of revenue that is yet underdeveloped and unexplored.

In Nigeria, over 95% of crop production is rain-fed, so rainfall is a critical factor for selecting crops, their planting time, the timing and intensity of input and labor use and subsequent yields.

Internet of things can be embraced for weather forecasting due to the undependability of weather patterns and to mitigate agricultural risks.

Agricultural Challenges in Nigeria

Agriculture in Nigeria has had its ups and downs in the past decade mostly because of poverty and lack of support from the government. Most farmers in Nigeria are poor and live in rural areas where they have no access to electricity and other things that are being enjoyed in the cities. These farmers rely on subsistence farming since they do not have the money to get the tools to go into large scale agricultural production which is known as commercial farming.

Internet of things would enable access to agricultural services, identification and access to markets for produce; management of rural transport for farmers, communication with extension services for information on agricultural practice and for information of weather forecasts to mitigate agricultural risks.

Nigerian government is trying to diversify from oil to agriculture. Agriculture is becoming the next oil especially in the area of livestock farming. Livestock farming is hard, capital and labor intensive especially in rural areas. Transportation of livestock produce to the exact consumers, tracking of livestock are some of the major problems faced by livestock farmers in developing countries like Nigeria. Internet of things can improve agriculture in Nigeria by keeping track of livestock especially in rural areas where there is collective grazing and animals are likely to get missing.

Fish farming is the most common and most glorified in agriculture in Nigeria now. According to *African Business Classroom*, it is estimated that five out of every ten Nigerians consume catfish on a weekly basis, meaning that at the very least 75 million catfish are bought and consumed every week in Nigeria alone (African Business classroom, 2010).

That makes the demand for the product very high. The potentials of catfish farming in Nigeria are endless, and established fish farmers say that it is possible to recoup investment outlay in 12 months. It has continued to improve the country in terms of employment and the generation of income for these farmers, their households and Nigeria which will reduce poverty. Getting the fishes to the consumers can be difficult at times because it is perishable, if not delivered on time, the fishes will get spoilt which will be a lost to the farmer. This creates a huge opportunity for cold storage and haulage of fresh fish with the use of refrigerated trucks and related logistics using Internet of things.

Agricultural production has been limited in Nigeria by pests, diseases and theft in both crops and livestock. To reduce and prevent it, sensors can be built in the fields which will inform the farmers of any attack on their crops or animals. There are some systems that can help farmers to make quality decisions in planning for the next farming season. Livestock sensors can be used to notify a farmer that an animal is sick or infected with a disease, allowing it to be taken away from the

herds on time before it spreads to the other animals. High acidity of soils can prevent proper yield of farm produce, so most of the farmers practice bush fallowing, but Internet of things can improve and detect the acidity of the soil with the use of soil sensors which will notify the farmers for high acidity or impending problems, allowing time to prevent poor yield before it happens.

Crude tools are mostly being used in Nigeria by farmers for cultivation which it requires more labor force if it is going to be for commercial farming. With the introduction of Internet of things, self-driving tractors can be used which can be controlled remotely, providing significant savings in labor cost. Adequate storage monitoring has been a problem, since it is hard to track the number of products that has been stored, Internet of things can solve this problem using a storage monitoring system apps in phones and tablets which can be used by farmers to monitor their stored produce.

It is believed that the Federal Ministry of Agriculture and Rural Development has put the demand for tomatoes in Nigeria at 2.2million tons and the supply at 800,000 tons. The ministry added that the actual quantity of tomatoes harvested is 1.5million tons but 700,000 tons are lost to post-harvest bottlenecks. Wastage of perishable foods, especially fruits and vegetables are persistent problem Nigerian farmers encounter (The Nigerian voice corp, 2010). Nigeria loses

over 60% of farm produce annually due to lack of storage and agro-processing facilities (The Nigerian voice corp, 2010). Even though agriculture remains the largest sector of the Nigerian economy and employs two-thirds of the entire labor force, the production hurdles have significantly stifled the performance of the sector. Over the past 20 years, value-added per capita in agriculture has risen by less than 1 percent annually. It is estimated that Nigeria has lost USD 10 billion in annual export opportunity from groundnut, palm oil, cocoa and cotton alone due to continuous decline in the production of those commodities and unavailability of technologies to monitor temperature and humidity to preserve them.

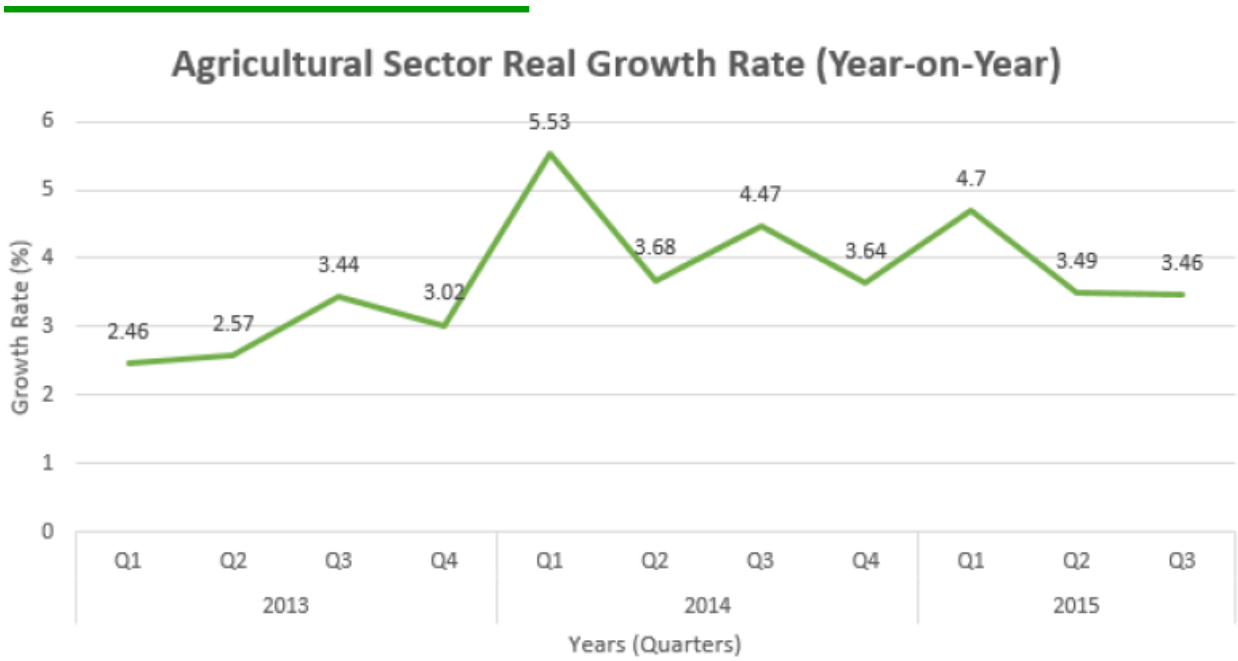

Blitzwatch Nigeria, 2015

CHAPTER FOUR

Implementation: I.O.T Storage Solution

In this section I develop an IoT solution for the proper storage of farm products. This section includes

1. A deployment architecture.
2. A detailed description of the architecture:
 - a. Required hardware (computers/servers/gateways etc.)
 - b. Required software
 - c. Required IoT devices
 - d. How devices are configured and deployed.
3. A description of the costs associated with acquiring and deploying the IoT solution.

Deployment Architecture

IoT architecture would consist of four stages. The stages are:

- Sensor Network
- Internet Gateway
- Data Processing
- Cloud Storage

Sensor Network

Sensors collect data from the environment or object under measurement and turn it into useful data.

For effective storage, sensors for temperature, proximity, moisture, humidity, camera light,

motion detection, time, odor, Acoustic, carbon dioxide sensors e.t.c would be deployed and

would be setup in a network of sensors.

The sensor network accomplishes two-way data transition and data acquisition. The monitoring nodes adopt wireless communication. The communication band is 433MHz/2.4GHz. The communication distance is about 1km. The data rate is 250kbps. The nodes support the integration of GPRS/CDMA terminals for the extended applications.

The sensor platform accomplishes universal application. The platform provides rich interfaces for the collection of digital data, analog data and pulse data. The analog data is voltage or current. The input range is 0-3.3V or 4mA-20mA. The platform is low power consumption. The platform is powered by 3.3V, 5V and 12V. The sensors are switched regularly and dynamically.

Internet Gateway

The data from the sensors starts in analog form. That data needs to be aggregated and converted into digital streams for further processing downstream. Data acquisition systems (DAS) perform these data aggregation and conversion functions. The DAS connects to the sensor network, aggregates outputs, and performs the analog-to-digital conversion. The Internet gateway receives the aggregated and digitized data and routes it over Wi-Fi, wired LANs, or the Internet, to Stage 3 systems for further processing.

Intelligent gateways can build on additional, basic gateway functionality by adding such capabilities as analytics, malware protection, and data management services. These systems

enable the analysis of data streams in real time. Although delivering business insights from the data is a little less immediate at the gateway than it would be when sent directly from the sensor/actuator zone, the gateway has the compute power to render the information in a form that is more understandable to business stakeholders.

Data Processing

This is where IT systems, which perform more analysis, come into play. IT processing systems may be in remote offices or other edge locations, but generally these sit in the facility or location where the sensors reside closer to the sensors, such as in a wiring closet, because IoT data can easily eat up network bandwidth and swamp your data center resources, it's best to have systems at the edge capable of performing analytics as a way to lessen the burden on core IT infrastructure. If you just had one large data pipe going to the data center, you'd need enormous capacity. You'd also face security concerns, storage issues, and delays processing the data. With a staged approach, you can preprocess the data, generate meaningful results, and pass only those on.

Cloud Storage

Data that needs in depth processing, and where feedback doesn't have to be immediate, gets forwarded to physical data center or cloud-based systems, where more powerful IT systems can

analyze, manage, and securely store the data. It takes longer to get results when you wait until data reaches the cloud, but you can execute a more in-depth analysis, as well as combine your sensor data with data from other sources for deeper insights. Information processing at this stage may take place on-premises, in the cloud, or in a hybrid cloud system, but the type of processing executed in this stage remains the same, regardless of the platform.

Possible Cloud Platforms Include:

- Amazon Web Services
- Azure
- IBM cloud services e.t.c

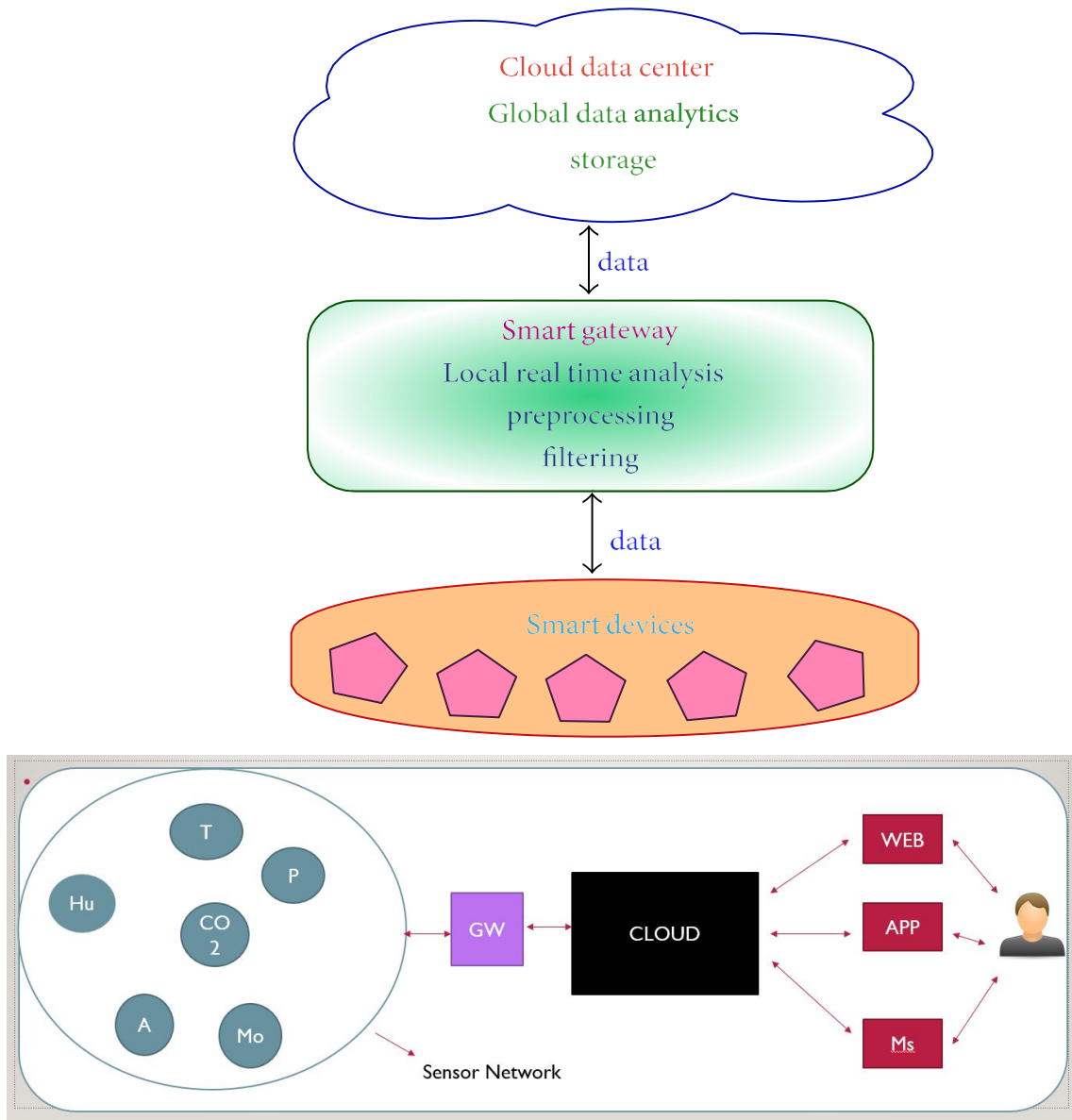

Storage System Solution Architecture For a 1200 per 1200 Sqr ft Storage Room

How The System Works

In this project the design includes a single microcontroller, temperature sensor, humidity sensor, smoke sensor, LDR, internet and a laptop. Apart from the server (Laptop) entire unit is placed within warehouse or storage unit.

The microcontroller (Raspberry PI) which is the control unit for each node collecting information would have a program embedded in it, which helps it to act based on information passed or supplied by sensors.

Temperature and humidity sensors check if there is any change in temperature and humidity within the warehouse or storage facility and the smoke sensor is used to detect any smoke or poisonous gases. The information provided by the sensors are processed by the microcontroller (Raspberry pi) and are interpreted based on program and values set. This is sent to web app (AWS green grass and app sync) where the user can view and control settings. Based on whatever value set in the program in the microcontroller sends out a notification to the end user, which in this case is the farmer. Below a flow chart showing user activity for storage monitoring system.

Deployment Overview

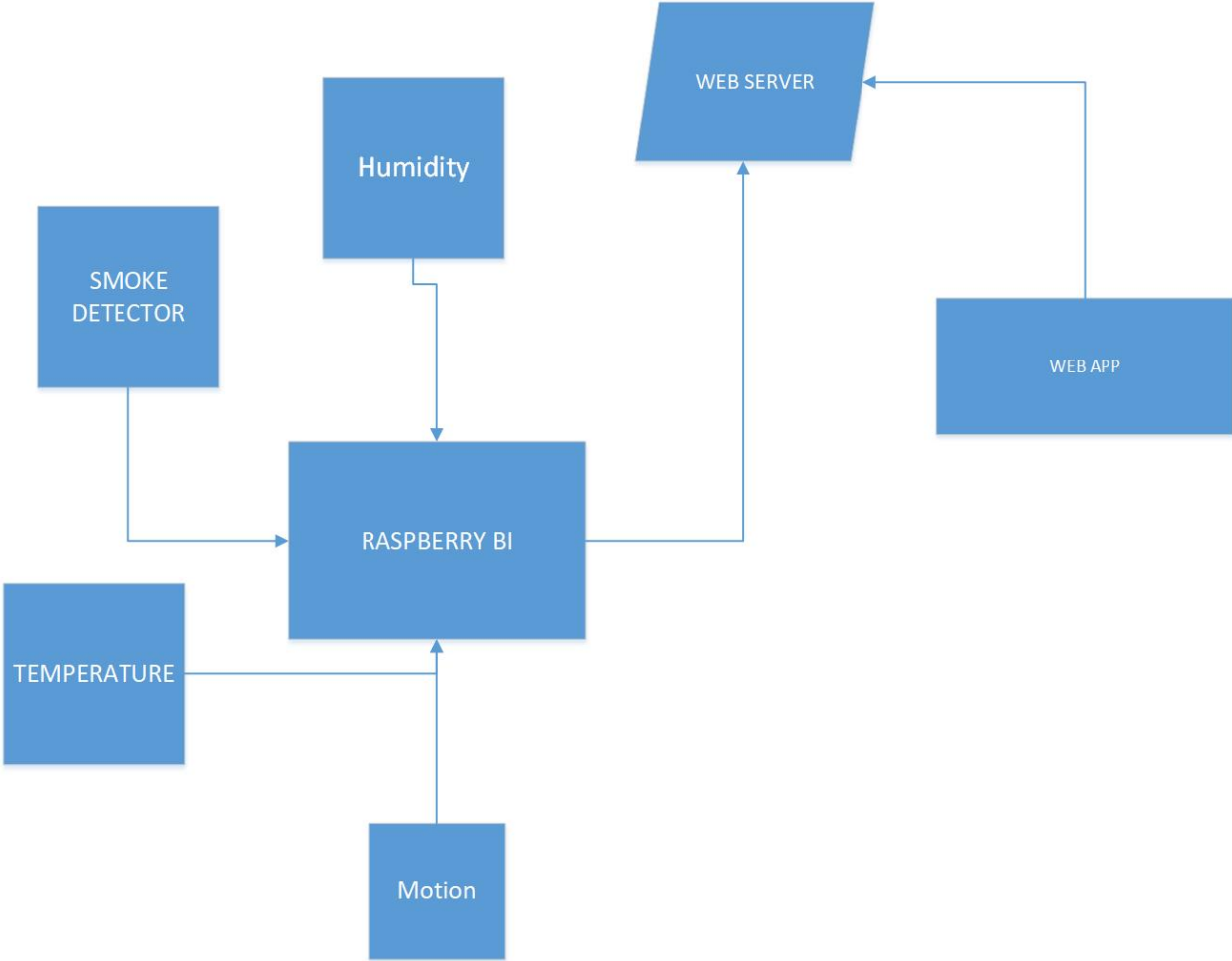

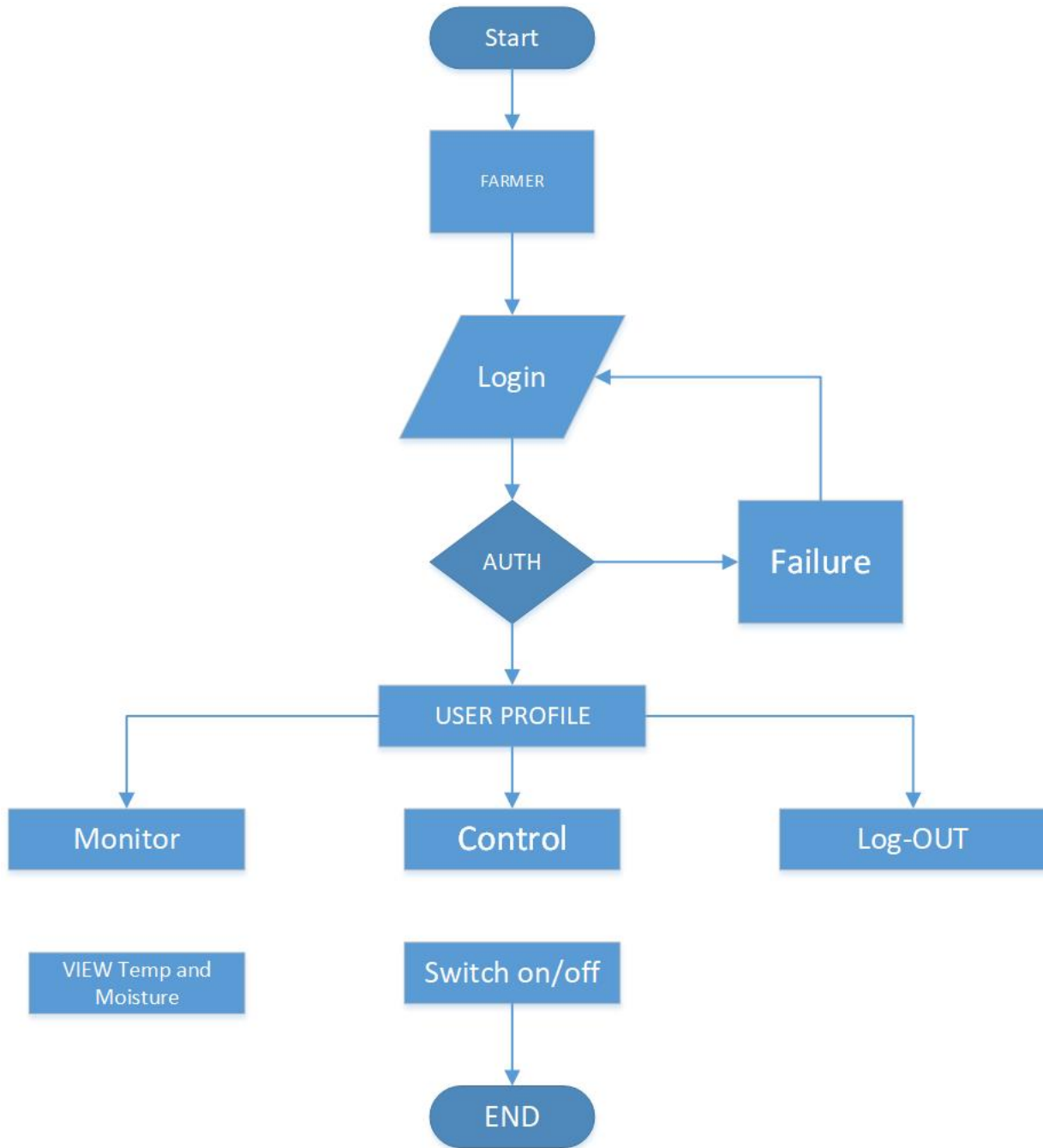

Work-Flow Diagram

HARDWARE SYSTEM REQUIREMENT

Hardware system Requirement Include

- 1) Raspberry pi
- 2) temperature sensor LM35DZ/NOPB Temperature Sensors (Zigbee Node)
- 3) Humidity Sensor HDC1000 (Zigbee Node)
- 4) Smoke Sensor
- 6) Motor
- 8) FAN
- 9) Relay board
- 10) Power Supply
- 11) Web SERVER

Software Requirements

Software system Requirement Include

- 1) Operating System Contiki
- 2) 3Rd Party Web Application (Build on AWS Solution)

Raspberry PI

A Raspberry Pi is a credit card-sized computer. Raspberry Pi is basically a device designed which acts as a microcontroller as well as a server. . Raspberry Pi may be slower than a modern laptop or desktop but is still a complete linux computer and provides all the expected abilities, at a low-power consumption level. It is an open hardware with an exception of Broadcom SoC(System on chip), which runs most of the components of CPU board, graphics, USB controller etc. Most of the projects made with raspberry pi are open and well documented.



RELAY

Relays are switches. They are also used to switch the incoming signals from one source to different destinations. They can also be used to perform Boolean and other logical operations in a computer.

Think of a relay as an electronic light switch. To turn the light on, flick the switch up. To turn the light off, flick the switch down. A light switch simply closes (or completes) an electrical circuit to turn on a light and opens (or breaks) a circuit to turn off the light. A relay does this same exact thing except that the switch is powered not by hand but by a low-power signal.

Temperature Sensor LM35DZ

The LM35 series are precision integrated-circuit temperature sensors, with an output voltage linearly proportional to the Centigrade temperature. LM35 is an IC temperature sensor with its output

proportional to the temperature. Here the sensor circuit is sealed and is not subjected to oxidation or any other process. Here temperature is measured more efficiently when compared with a thermistor. Range of the temperature is between -55°C to 150°C .

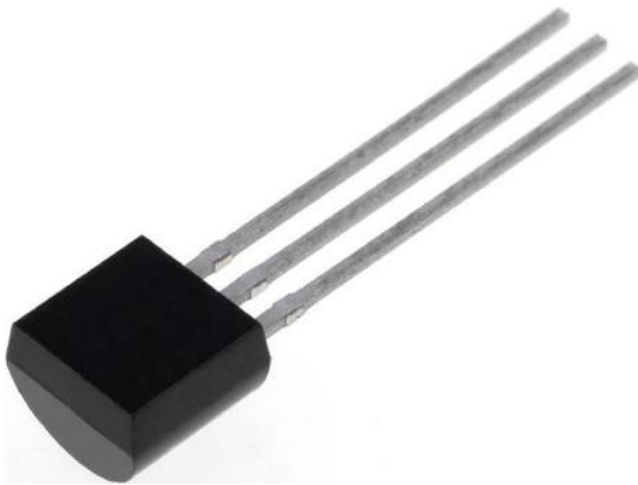

HDC 1000 Humidity Sensor

The HDC1000 is a digital humidity sensor with integrated temperature sensor that provides excellent measurement accuracy at very low power. The device measures humidity based on a novel capacitive sensor. The humidity and temperature sensors are factory calibrated. The innovative WLCSP (Wafer Level Chip Scale Package) simplifies board design with the use of an ultra-compact package. The sensing element of the HDC1000 is placed on the bottom part of the device, which makes the HDC1000 more robust against dirt, dust, and other environmental contaminants. The HDC1000 is functional within the full -40°C to $+125^{\circ}\text{C}$ temperature range.

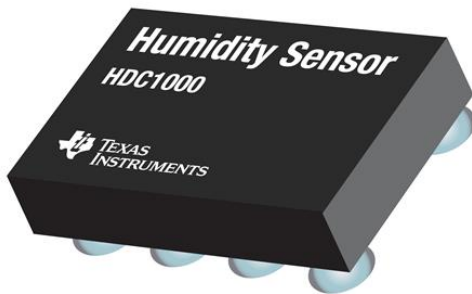
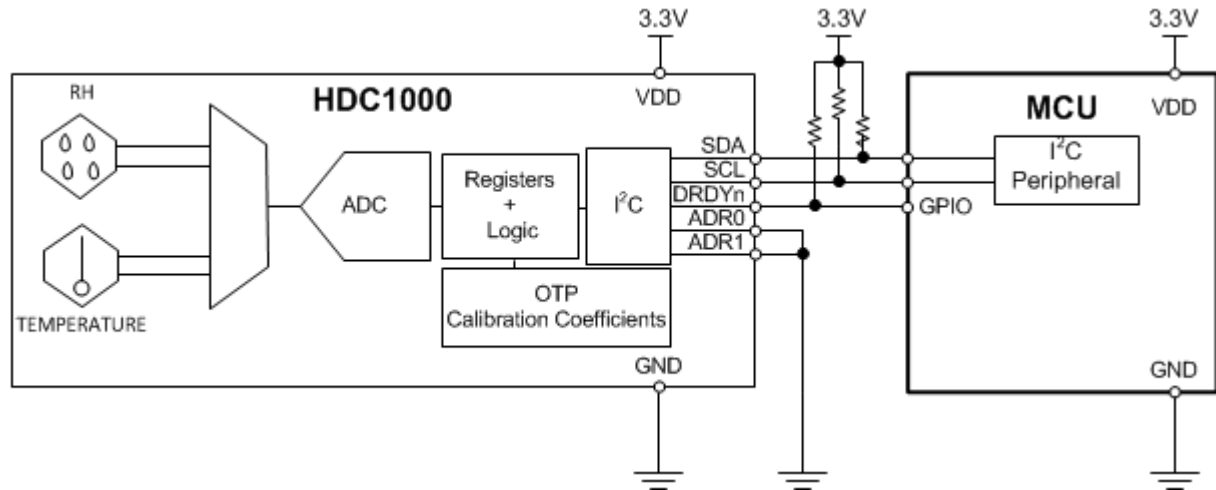

Contiki Operating System

Contiki is an open source operating system for the Internet of Things. Contiki connects tiny low-cost, low-power microcontrollers to the Internet. Contiki is a powerful toolbox for building complex wireless systems. The Contiki system includes a network simulator called Cooja, which simulates networks of Contiki nodes. The nodes may belong to either of three classes: emulated nodes, where the entire hardware of each node is emulated, Cooja nodes, where the Contiki code for the node is compiled for and executed on the simulation host, or Java nodes, where the behavior of the node must be reimplemented as a Java class. One Cooja simulation may contain

a mix of nodes from any of the three classes. Emulated nodes can also be used to include non-Contiki nodes in a simulated network.

Raspbian is pre-installed with the software for programming and other purposes. It is basically having python, Scratch, Sonic Pi, Java etc. Also, it acts as an easy installer.

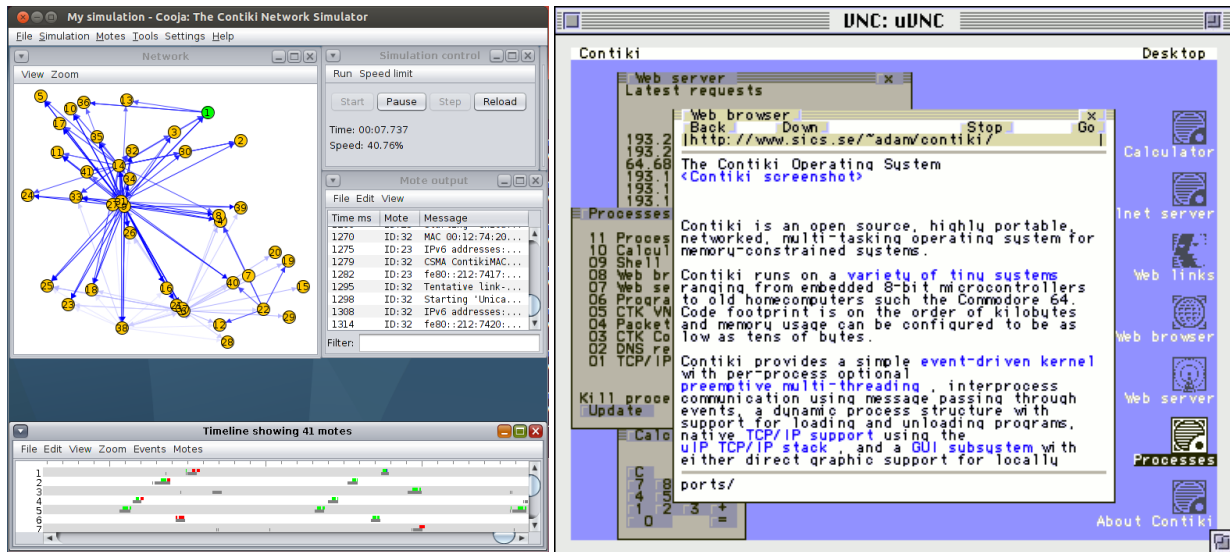

WEB Service

A Web service is a method of communication between two electronic devices over a network. It is a software function provided at a network address over the Web with the service always on as in the concept of utility computing. The user or farmer will be given an web URL through which one can access the dashboard of this project. One can use the service either in a cell phone or a laptop and computer.

3Rd Party Web Application (AWS GreenGrass and AppSync)

AWS Greengrass is software that lets you run local compute, messaging, data caching, sync, and ML inference capabilities for connected devices in a secure way. With AWS Greengrass, connected devices can run AWS Lambda functions, keep device data in sync, and communicate with other devices securely, even when not connected to the Internet. Using AWS Lambda, Greengrass ensures your IoT devices can respond quickly to local events, use Lambda functions running on Greengrass Core to interact with local resources, operate with intermittent connections, stay updated with over the air updates, and minimize the cost of transmitting IoT data to the cloud.

AWS Greengrass seamlessly extends AWS to devices, so they can act locally on the data they generate, while still using the cloud for management, analytics, and durable storage. With Greengrass, you can use familiar languages and programming models to create and test your device software in the cloud, and then deploy it to your devices. AWS Greengrass can be programmed to filter device data and only transmit necessary information back to the cloud. AWS Greengrass authenticates and encrypts device data at all points of connection using the security and access management capabilities of AWS IoT Core. AWS AppSync automatically updates the data in web and mobile applications in real time, and updates data for offline users as soon as they reconnect. AWS AppSync makes it easy to build collaborative mobile and web applications that deliver responsive, collaborative user experiences.

You can use AWS AppSync to build native mobile and web apps with iOS, Android, JavaScript and React Native. Get started by going to the AWS AppSync console, specify the data for your app with simple code

statements, and AWS AppSync will manage everything needed to store, process, and retrieve the data for your application.

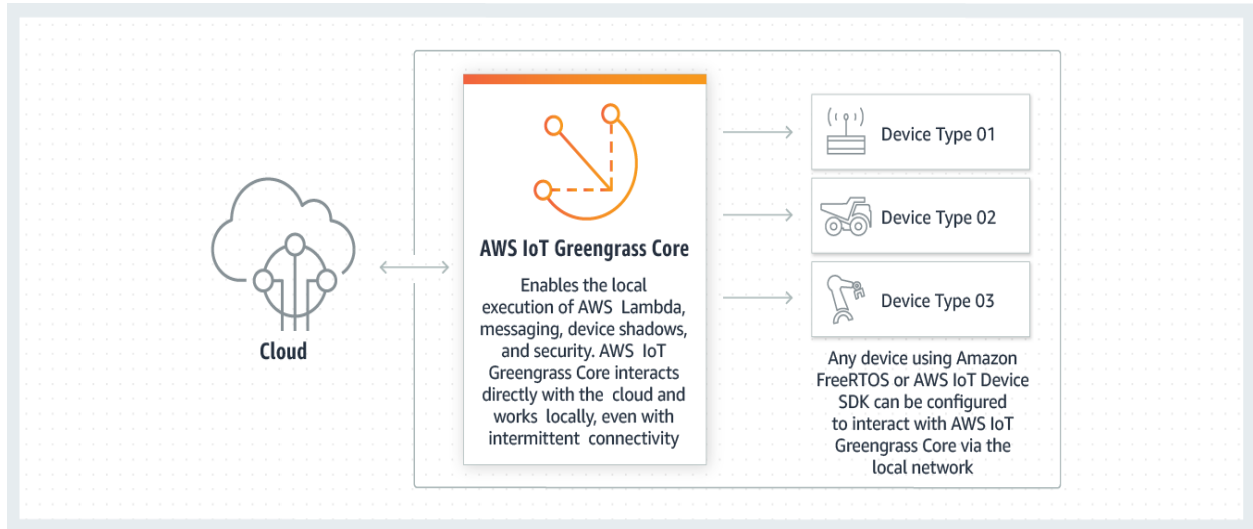

Amazon Web Services, 2014

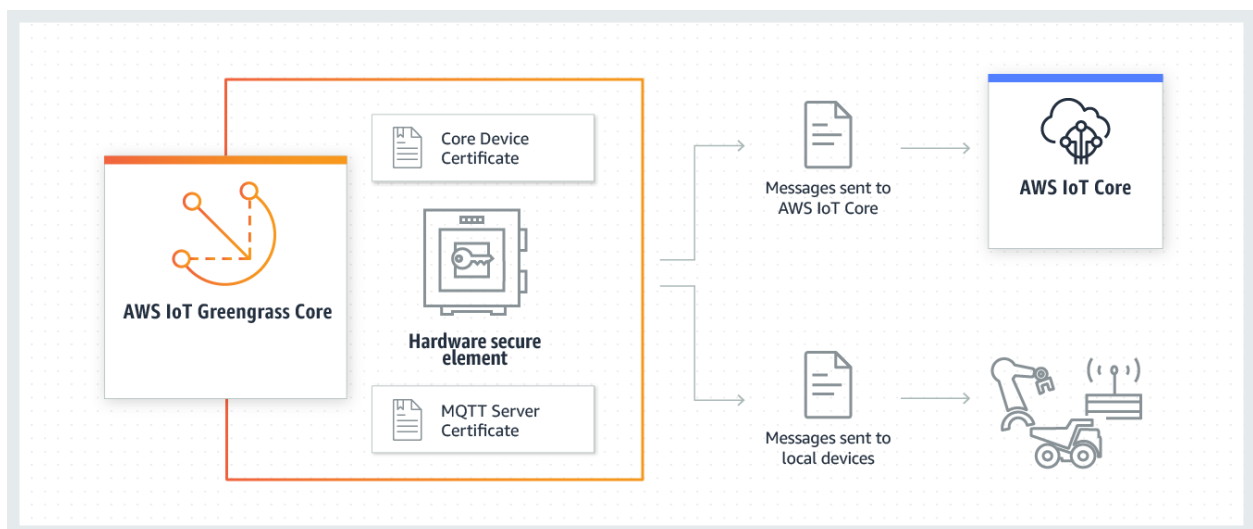

Amazon Web Services, 2014

Cost of Implementation

IoT systems dramatically benefit from localized data collection. The more granular the data localization, the better business decisions can be. Therefore, it is imperative for the IoT sensor devices to be cost effective to enable widespread deployments and to be able to reduce the overall business costs. Due to this desire for larger unit volume deployments, connected sensor devices need to be as low cost as possible – cost competitive to other commodity devices with similar hardware features and capabilities. IoT is a complex system solution. To truly achieve cost effectiveness, the whole system cost has to be optimized – focusing on cost optimization of a single component may not result in the lowest overall system cost over the product’s intended lifespan.

When considering the cost of implementation, the following areas should be put into consideration;

- Hardware
- Infrastructure
- Application
- Warehouse/Storage

Hardware - Seventy percent (70%) the overall cost of Implementing the whole IoT system is usually the hardware cost (Andrei Klubnikin, 2016). The cost of sensors, micro controllers, routers, cables, power supply e.t.c account for majority of implementation cost of IoT. Scale of the project and size would determine the quality and number of hardware required.

Infrastructure - The components of IoT infrastructure include:

- **Middleware.** According to Intel, 85% of gadgets were not designed to talk to each other or connect to the Internet. Middleware (or gateway) is a computer program that brings IoT parts together, enabling communication between smart sensors and the application layer;
- **Network.** The Internet of Things won't work without a highly scalable wireless network infrastructure, low latency and high-speed connections;
- **Cloud-based or data center infrastructure** - Here I am referring to storage solutions and software that boils down gigabytes of raw data to what's truly meaningful. The Internet of Things startups typically leverage smart gadget connectivity and data analysis through PaaS solutions built by Intel, Amazon or Microsoft.

Applications – Here I am referring to How much does it cost to develop an app that enables users to operate connected devices from a smartphone, tablet, PC or wearable device? Just like with hardware, it depends on the size of your project.

Estimated Cost of Implementation of Proposed Solution / year

ITEM / 1		PRICE/USD	
Rasberry BI		35	
LM35DZ/NOPB Temperature Sensors		10	
HDC1000		11	
Relay Board (ESP8266 MCU)		20	
Smoke Sensor (P1010 smoke sensor		30	
Alternative Power Supply (Generator 3800watts		500	
120Volts/240Volts)			
Contiki Operating System		0	
Server - laptop with 8gb RAM		700	
	TOTAL	1306	\$1306 (One time cost)
SERVICES/ Operational Cost			
ISP	80 (estimated)	\$80(per month)	
Web Service AWS GreenGrass / device yearly	1.49 daily	50 (per month)	
AWS APPSync / 1000 queries	0.5 daily	50 (per month)	
Alternative Source of Power (Absence of power supply)/month	70 (estimated)	70 (per month)	
Total		\$250 (per month)	\$3000 (yearly cost)
	1st year cost total		\$4,306
	2nd year cost		\$3,000

ESTIMATED COST AND RETURNS OF YAM PRODUCTION/HECTARE

According to research carried out by Zaknayiba D.B and L. Tanko in the Karu Local Government Area of Nasarawa State, Nigeria, which is a major yam farming region in Nigeria, shows the estimated cost and income made from yam harvesting per hectare of land. Data were collected using well-structured questionnaire and interview schedules between January and April 2012. Information collected include socio-economic characteristics of farmers such as age, gender, educational level, marital status, household size, access to credit, extension contact, costs and returns and constraints faced by yam farmers in the study area. Data were analyzed using descriptive statistics and gross margin analysis.

The following were derived from the above research.

The gross margin is the difference between the gross farm income (GFI) and the total variable cost (TVC). Algebraically,

$$GM = GFI - TVC \quad (1)$$

Where GM = Gross margin, GFI = Gross farm income, TVC = total variable cost.

The Net farm income is the difference between the gross margin (GM) and total fixed costs (TFC).

$$NFI = GM - TFC$$

Where NFI = Net farm income, TFC = Total fixed cost and GM is as previously defined.

Below is a table showing the estimated cost and income realized from yam harvesting per hectare of land.

Average costs and returns per hectare of yam produced in the study area

Costs and returns	Amount (₦/ha)	% of total cost
(A) Variable costs		
Labour	85,356.4	71.3
Yam seed	15,945.8	10.4
Herbicide	8,205.0	6.6
Insecticide	854.9	0.5
Fertilizer	11,893.2	9.7
Total variable cost	122,255.3	98.4

(B) Fixed costs

Hoes	490.6	0.4
Axes	34.8.6	0.3
Cutlass	569.3	0.5
Basket	46.2	0.4
Total fixed costs	1,874.7	1.6
Total costs	124,129.3	100.0
Gross returns	271,166.7	
Net farm income	147,037.4	
Returns on investment	2.19	

(Zaknayiba D.B and L. Tanko, 2012)

ESTIMATED RETURN ON INVESTMENT/HECTARE

Information obtained from above research, estimates net profits made per hectare of yam is about \$2000(270,000 naira) per hectare. This brings yearly net profit to about \$24,000.

60% of the farm produce do not get to the end consumer due to wastage led by inadequate storage facilities and preservation. (Harvest Protection Network, Bitzwatch, 2015). Based on this statement yearly profits are based of 40% of harvested produce. Below is a table showing what the yearly profit would be if no wastage occurred.

percentage of farm Produce	yearly net income
40 percent of produce	\$24000
100 percent of produce	\$60,000

Projecting Implementing IOT storage solution can reduce the percentage of wastage of produce from 60% to 40%, this would lead to increase in profit margins. Looking at the table below.

percentage of farm Produce	yearly net income
40 percent of produce	24000

60 percent of produce	36,000
100 percent	60,000

This results in almost a 50% increase to yearly revenue at an additional cost of \$4,306 required to implement I.O.T storage system.

After a year of implementing the I.O.T storage solution initial investment of \$4,306 would be recovered, with an additional \$7,694 increase in profit versus running storage warehouse without storage solution.

ESTIMATED RETURN ON INVESTMENT/0.53 HECTARE OF LAND

The average size of a small size farm in Nigeria is estimated to be about 0.53 hectares (F.A.O, 2012). Using the above model, below is a table estimating projected cost and returns for a small farm in Nigeria.

Costs and returns	Amount (₦/ha)	% of total cost
(A) Variable costs		
Labour	45,238.89	71.3
Yam seed	8,451.27	10.4
Herbicide	4,348.65	6.6
Insecticide	453.097	0.5
Fertilizer	6,303.40	9.7
Total variable cost	64,795.31	98.4
(B) Fixed costs		
Hoes	260.018	0.4
Axes	18.444	0.3
Cutlass	301.729	0.5
Basket	24.486	0.4
Total fixed costs	993.59	1.6
Total costs	65,788.53	100

Gross returns 143,718.35

Information obtained from above research, estimates net profits projected per 0.53 hectare of yam farm land is about \$1064(143,718.35 naira) per 0.53 hectare. This brings yearly net profit to about \$12,768.

60% of the farm produce do not get to the end consumer due to wastage led by inadequate storage facilities and preservation. (Harvest Protection Network, Bitzwatch, 2015). Based on this statement yearly profits are based of 40% of harvested produce. Below is a table showing what the yearly profit would be if no wastage occurred.

percentage of farm Produce	yearly income	net
40 percent of produce	\$12,768	
100 percent of produce	\$31,920	

Projecting Implementing IOT storage solution can reduce the percentage of wastage of produce from 60% to 40%, this would lead to increase in profit margins. Looking at the table below.

percentage of farm Produce	yearly income	net
40 percent of produce	12,768	
60 percent of produce	19,152	
100 percent	31,920	

This results in almost a 50% increase to yearly revenue at an additional cost of \$4,306 required to implement I.O.T storage system.

After a year of implementing the I.O.T storage solution initial investment of \$4,306 would be recovered, with an additional \$2,694 increase in profit versus running storage warehouse without storage solution.

CONCLUSION

This research has highlighted potential applications of IoT in agriculture related to storage and preservation. It has shown the major challenges of IOT in agriculture in rural communities in developing countries like Nigeria. Agriculture in rural area and farmers are of importance when it comes to socialist upgrading reform.

IoT works in different areas of farming to improve time efficiency, water management, crop monitoring, soil management, control of insecticides and pesticides, temperature control etc. It also minimizes human efforts, simplifies techniques of farming and help elevate the agricultural sector.

This study has shown the benefits that can be derived from IoT in agricultural storage. The study is meant to encourage the policy on the acceptance of IoT in rural development and agriculture in developing countries. This project can also be utilized by software developers of new IoT technologies to build country-specific technologies based on the identified challenges and situation in developing countries.

FUTURE WORK

IOT can be applied to a lot of aspect of agriculture. Some areas might include;

- 1) Precision Agriculture - is a farming management concept based on observing, measuring and responding to inter and intra-field variability in crops. The goal of precision agriculture research is to define a decision support system (DSS) for whole farm management with the goal of optimizing returns on inputs while preserving resources (Nicole Rogers,2014).
- 2) Price analysis – An in-depth price analysis of IoT Systems and how these prices affect IoT use in the agricultural sector.
- 3) Application of IoT to Rearing of Animals. GPS tracking software/mechanism can be used to identify animal location. This can help reduce theft, detect injury/sickness e.t.c

REFERENCES

1. The application of internet of things in agricultural means of production supply chain management by Xiaohui Wang and Nannan Liu. (2014).
2. Role of IoT in Agriculture by Vinayak N. Malavade, Pooja K. Akulwar. (2016).
3. Field Monitoring and Automation Using IOT in Agriculture Domain by J. Naren. (2016).
4. Post-harvest food losses estimation- development of consistent methodology by Jaspreet Aulakh and Anita Regmi. 2016.
5. The Internet of Things in Agriculture for Sustainable Rural Development by Josephat Kalezhi and Nomusa Dlodlo. (2015).
6. The agricultural foundations of civilization by Wessel, T. Agric Hum Values (1984) 1: 9.
<https://doi.org/10.1007/BF01530609>
7. The Challenges of Agriculture and Rural Development in Africa: The Case of Nigeria by Adejuwon K.A and Nchuchuwe F.F. (2012).
8. Reducing Postharvest Losses during Storage of Grain Crops to Strengthen Food Security in Developing Countries by Deepak Kumar and Prasanta Kalita

9. Zigbee implementation in intelligent agriculture based on internet of things by Xiaojing, Z., Yuangua, L. (2012).
10. Becoming technological advanced - IOT applications in smart agriculture by Joe-Air Jiang. (2014).
11. Uses of Information and Communication Technology (ICT) in Agriculture and Rural Development in Sub- Saharan Africa: Experiences from South Africa and Kenya by Maumbe, B. M.; Okello, J. (2010).
12. Zigbee Based Real - Time Monitoring System of Agricultural Environment by Sumit P. Goyal, Dr. Archana Bhise. (2014).
13. Application of IoT in Agricultural by Peng Qin, Zhao Lu and Tao Zhu. (2015).
14. Research on Fresh Agricultural Products Cold Chain Logistics Certification System by Xingang Weng, Jiuyi An. (2015).
15. How much does it cost to build an IoT Solution by Andrei Klubnikin (2016).
16. Study on an Agricultural Environment Monitoring Server System using Wireless Sensor Networks by Jeonghwan Hwang, Changsun Shin and Hyun Yoe (2010).
17. Internet of Things Exploring and Securing a Future Concept by cristian bude and andreas kervefors (2015).

18. Wireless Sensor Based Remote Monitoring System for Agriculture Using ZigBee and GPS
by G. V. Satyanarayana and SD.Mazaruddin.
19. Amazon Web Services. <https://aws.amazon.com>
20. Sensors for Grain Storage authored by Suresh Neethirajan (2007).
21. Real time monitoring in agricultural warehouse using IOT by Shreyas, Nadeem, Sadhan
2017
22. Study on an Agricultural Environment Monitoring Server System using Wireless Sensor
Networks by Jeonghwan Hwang, Changsun Shin and Hyun Yoe 2010.
23. New sensor for testing food freshness could spell the end of expiration dates by Arielle
Duhaime-Ross, from <https://qz.com/58012/new-sensor-for-testing-food-freshness-could-spell-the-end-of-expiration-dates/>
24. New plastic electronics can greatly reduce food waste worldwide. Retrieved from
<https://www.tue.nl/en/university/news-and-press/news/new-plastic-electronics-can-greatly-reduce-food-waste-worldwide/#top>
25. One third of all food wasted. Retrieved from <http://www.unric.org/en/food-waste/27133-one-third-of-all-food-wasted>
26. Verisense. Retrieved from <https://verisolutions.co/technology/#verisense>
27. BeanIOT. Retrieved from <http://www.beaniot.com/>
28. Meeting wide-area agricultural data acquisition and control challenges through Zigbee
wireless network technology. Retrieved from
<https://elibrary.asabe.org/abstract.asp?aid=21879>

29. From farm to dustbin: Plight of Nigerian farmers battling post -harvest losses. Retrieved from <http://punchng.com/from-farm-to-dustbin/>
30. Agriculture in Nigeria. Retrieved from <https://total-facts-about-nigeria.com/agriculture-in-nigeria.html>
31. Food Storage. Retrieved from <https://en.wikipedia.org/wiki/Foodstorage>
32. How IoT benefits agriculture. Retrieved from <http://iot.intersog.com/blog/how-internet-of-things-benefits-agriculture>
33. Major problems of food & agriculture in Nigeria by the Nigerian voice corporation 2010.
34. Costs and Returns Analysis of Yam Production among Small Scale Farmers in Karu Local Government Area, Nasarawa State, Nigeria by Zaknayiba D.B.* and L. Tanko.
35. Small Family Farms Data Portrait, by Food and agriculture Organization of the united nations.